

DELPHI WALL PACK (SEMI CUTOFF)

1

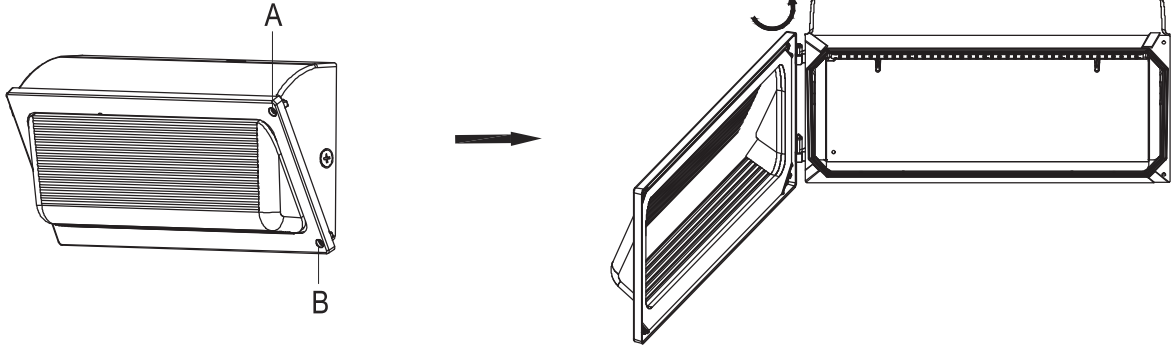

Loosen the 2x M5 crews (A/B) and open the fixture.

2

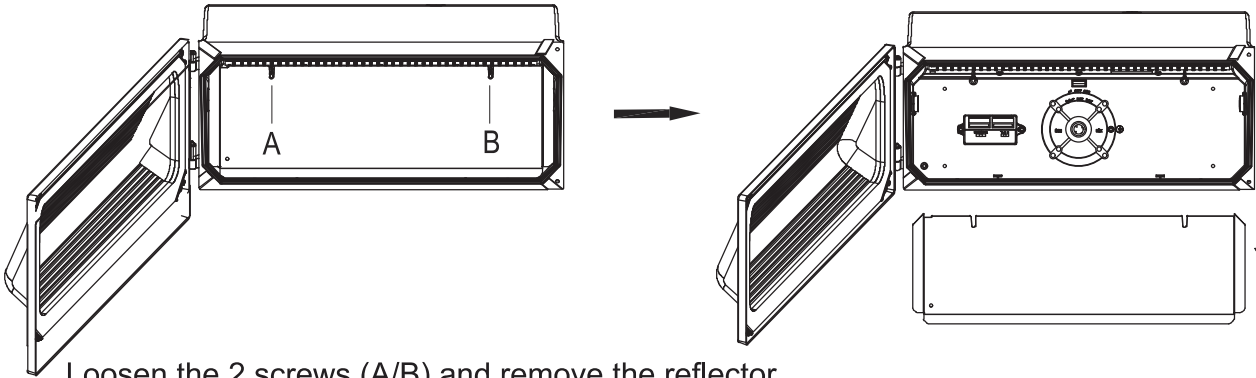

Loosen the 2 screws (A/B) and remove the reflector.

3

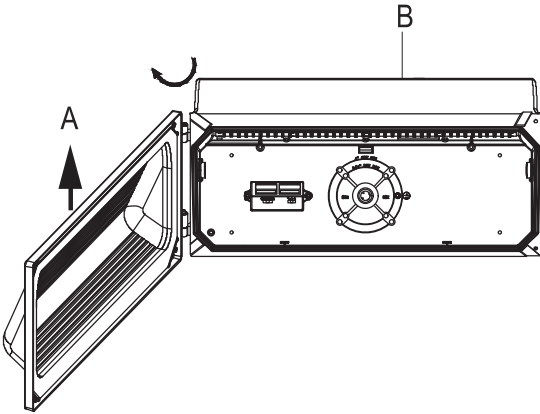

Separate part A and B and set part A aside.

4



Prepare the back housing for mounting by drilling or knocking out the appropriate hole.

Unscrew the 1/2 screw if needed.

DELPHI WALL PACK (SEMI CUTOFF)

5

CCT & Watt Select

5.1 Fix the back housing to the junction box
 5.2 Connect wires as per the wiring diagram (P3)
 5.3 Select desired color temperature and wattage

B

5.1 Fix the back housing on the wall
 5.2 Connect wires as per the wiring diagram (P3)
 5.3 Select desired color temperature and wattage

6

A screw

B screw

Put back the reflector and tighten the 2 screws

7

A

B

Put part A back onto the hinge of part B.
 Check the hinge for secure.

8

Remove the waterproof plugs.
 Connect to the main electricity and check if the unit works properly.

